



Differential pressure gauge, copper alloy or stainless steel Scale ranges from 0.6 ... 1,000 bar Models 711.12, 713.12, 731.12 and 733.02



for further approvals
see page 3

Applications

- Heating, ventilation and air-conditioning
- For gaseous and liquid media that are not highly viscous or crystallising
- Models 731.12 and 733.02 also for aggressive media
- Models 713.12 and 733.02 with liquid-filled case are suitable for high dynamic pressure loads and vibrations

Special features

- Scale ranges from 0 ... 0.6 bar to 0 ... 1,000 bar
- Two process connections and two independent pointers
- Differential pressure display with moving dial
- Cost-effective and reliable



Differential pressure gauge model 711.12

Description

The differential pressure gauge is based on two independently operating Bourdon tube measuring systems. The instrument is therefore able to show the pressure from two measuring points and the resulting differential pressure on one display.

Differential pressure display

The standard version is designed with two pointers and a gauge pressure scale. The pointer for the minus connection is connected to an additional moving dial. On the scale of the moving dial, the differential pressure ($\pm 50\%$ of the main scale's full scale value) can be read directly. Alternatively, in the version without additional moving dial, the differential pressure is not indicated.

In the version with a subtracting movement, the differential pressure is indicated with only one pointer (the individual pressures of plus and minus connection are not displayed). The variance of scale versions ensures an optimal readability of all operating parameters.

The models 731.12 and 733.02, with wetted parts from stainless steel, have been specifically designed for the requirements in the process industry.

For harsh operating conditions (e.g. vibration), the instruments are also available with an optional liquid filling.



Standard version

Version

Two independent measuring systems, process connections in line

Nominal size in mm

100, 160

Accuracy class

1.6

Scale ranges

0 ... 0.6 to 0 ... 1,000 bar

Scale range must be selected in relation to the maximum total pressure applied!

In heating systems with circulating pumps, the total pressure applied is usually defined as equal to the hydrostatic pressure plus the pump pressure.

In order to ensure a good readability, the differential pressure should not drop below 1/6 of the full scale value.

When ordering specify both pressures:

a) maximum total pressure applied, b) differential pressure

Pressure limitation

Steady: Full scale value

Fluctuating: 0.9 x full scale value

Short time: 1.3 x full scale value

Permissible temperature

Ambient: -20 ... +60 °C

Medium: Model 711.12: +60 °C maximum (soft soldered)
+100 °C maximum (brazed)

Model 731.12: +200 °C maximum

Temperature effect

When the temperature of the measuring system deviates from the reference temperature (+20 °C): max. $\pm 0.4 \%$ /10 K of full scale value

Ingress protection per EN/IEC 60529

IP33

Process connection

Model 711.12: Copper alloy

Model 731.12: Stainless steel

Lower mount, 2 x G 1/2 B (male), SW 22

Plus connection at back, minus connection at front (identified with \oplus and \ominus)

Pressure elements

Model 711.12:

< 100 bar: Copper alloy, C-type, soft soldered

\geq 100 bar: Stainless steel, helical type, brazed

Model 731.12:

Stainless steel, all pressure ranges, welded

Movement

Copper alloy, wear parts argentan

Dial

Aluminium, white, black lettering

Pointer

\oplus side: 1 standard pointer at front, aluminium, black

\ominus side: 1 scale pointer at back, aluminium, red, with 50 % of the scale range, respectively, as \oplus and \ominus differential pressure display

Case

Steel, black

Window

Instrument glass

Ring

Slip-on bezel, steel, black

Options

- Other process connection
- Case and ring from stainless steel
- Design with duplex display ("duplex pressure gauge")
- NS 100: Liquid filling (model 713.12)
- NS 100: Measuring system, case, ring from stainless steel and liquid filling (model 733.02), medium temperature resistant up to max. 100 °C
- Subtracting movement (one pointer for differential pressure display), location of reversed pressure connection: \oplus connection at front, \ominus connection at back, copper alloy or stainless steel
- Panel or surface mounting flange
- Electrical switch contacts (data sheet AC 08.01), subtracting movement



Dimensions in mm

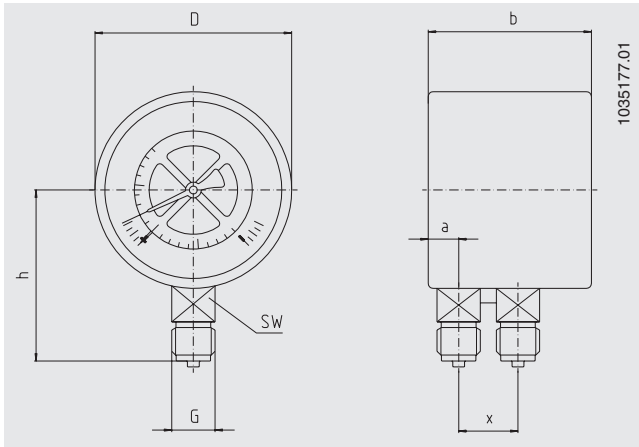

NS	Dimensions in mm							Weight in kg
	a	b	D	G	h ±1	X	SW	
100	15.5	82	100	G ½ B	87	32	22	1.00
160	15.5	86.5	160	G ½ B	118	32	22	1.60

Process connection per EN 837-1 / 7.3

Approvals

Logo	Description	Country
	EU declaration of conformity Pressure equipment directive	European Union
	EAC (option) Pressure equipment directive	Eurasian Economic Community
	GOST (option) Metrology, measurement technology	Russia
	KazInMetr (option) Metrology, measurement technology	Kazakhstan
-	MTSCHS (option) Permission for commissioning	Kazakhstan
	BelGIM (option) Metrology, measurement technology	Belarus
	UkrSEPRO (option) Metrology, measurement technology	Ukraine
	Uzstandard (option) Metrology, measurement technology	Uzbekistan
-	CPA Metrology, measurement technology	China
-	CRN Safety (e.g. electr. safety, overpressure, ...)	Canada

Certificates (option)

- 2.2 test report
- 3.1 inspection certificate

Approvals and certificates, see website